

TECHNICAL GUIDE

Single Package Heat Pump with Electric Heat 14 SEER (13.4 SEER2) - R-410A Three-Phase - 3 to 5 nominal ton - 460 V Models: PHE4*36 to 60



Assembled at a facility with
an ISO 9001:2015-certified
Quality Management
System

Due to continuous product improvement, specifications are subject to change without notice.

Visit us on the web at

www.simplygettingthejobdone.com

Additional rating information can be found at

www.ahridirectory.org

Warranty summary

Standard 1-year limited parts warranty.

Standard 5-year limited compressor warranty.

See the limited warranty certificate in the *User's Information Manual* for details.

Description

These packaged cooling and heating heat pumps are designed for outdoor installation. Only utility and duct connections are required at the point of installation.

Features

- **Operating efficiency** - All PHE4 heat pump models are rated at 14.0 SEER (13.4 SEER2) and 8.0 HSPF (6.7 HSPF2) for cooling and heating operation.
- **On-site flexibility** - All model sizes use a compact design cabinet in one of two footprints. This provides installer flexibility for placing the correct capacity unit on curbs or pads with the smallest footprint after the internal load has been determined. Field-convertible duct connections from side shot to down shot allow the installer to have greater flexibility with less inventory.
- **Lower installation cost** - Installation time and costs are reduced by easy power and control wiring connections. The small base dimension means less space is required on the ground or roof. All units are completely wired, charged with R-410A refrigerant, and tested before shipment. Test stations using a state-of-the-art computerized process system are used to ensure product quality. Refrigerant charge and component part numbers are verified using computers during assembly. Vital run test statistics such as system pressure, motor currents, air velocity and temperature, unit vibration, and gas system safeties are monitored and recorded by the system to ensure unit performance. Equal size side supply and return duct connections allow easy connection of ducts to match low crawl spaces without transition pieces.
- **Utility connections made easy** - Electric utility access is provided through the bottom or side of the unit. Utility connections can be made quickly and with a minimum amount of field labor. A field-supplied and field-installed electrical disconnect switch must be installed.
- **Convertible airflow design** - The bottom duct openings are covered when they leave the factory, ready to be used for a side supply and side return application. If a bottom supply and bottom return application is required, remove the two panels from the bottom of the unit and place them in the side supply and side return duct openings. No panel cutting is required and no accessory panel is necessary. The convertible airflow design allows for maximum field flexibility and minimum inventory.
- **Condensate pan** - A corrosion-resistant, long-lasting, water-tight pan is positioned below the indoor coil to collect and drain all condensate, preventing buildup of stagnant condensate. The condensate pan conforms to ASHRAE 62-19 standards (Ventilation for Acceptable Indoor Air Quality).
- **Condensate drain** - The 3/4 in. NPT female connection is rigidly mounted to ensure correct fit and leak-tight seal.
- **Durable finish** - The cabinet is made of G90 galvanized steel with a powder paint coating for appearance and protection. The pretreated galvanized steel provides a better paint-to-steel bond, which resists corrosion and rust creep. The powder paint finish ensures less fading when exposed to sunlight, and provides superior corrosion resistance. The powder paint finish is 1,000 h salt spray tested.

- **Full perimeter base rails** - The easily removable base rails provide a solid foundation for the entire unit and protect the unit during shipment. The rails provide forklift access from all sides, and rigging holes are also provided so an overhead crane can be used to place the units on a roof. On applications where the unit is placed on a pad, the base keeps the unit off the pad to deter corrosion. On applications where height is limited, the base rails can be removed by removing two screws in each corner.
- **Attractive appearance** - A single-piece top cover containing a top-discharge outdoor fan arrangement requires less square footage on installation and provides a wider variety of installations. The one-piece design adds greater water integrity. Rounded corners with water drip edges add to the attractive appearance and provide cut protection to the installer.
- **Top discharge** - The top-discharge outdoor fan does not disrupt neighboring areas or dry out vegetation surrounding the unit. The warm air from the top mounted fan is blown up and away from the structure and any landscaping.
- **Outdoor coil grille** - All models use a stamped slotted design that provides superior impact protection against small objects during transit and after installation.
- **Low operating sound level** - The upward airflow carries the normal operating noise up and away from the living area. The rigid top panel effectively isolates noise. The isolator mounted compressor and the rippled fins of the outdoor coil muffle the normal fan motor and compressor operating sounds. The unique formed base pan also aids in sound attenuation with its structural design.
- **Low maintenance** - Long-life, permanently lubricated outdoor fan motor bearings and indoor blower motor bearings need no annual maintenance, adding greater reliability to the unit. The slide-out blower assembly and indoor coil assembly can be easily removed for cleaning or service.
- **Fan system** - All models operate over a wide range of design conditions with a standard ECM indoor blower motor. These units easily match all types of applications and provide greater on-site flexibility to match comfort requirements. The cooling speed and heating speeds are factory set at test design conditions but can be field adjusted. This allows for maximum comfort capabilities.
- **Loss of charge switch** - All models include a loss of charge switch to provide safe shutdown of the compressor.
- **Simple control circuit** - A printed circuit board contains a status or diagnostic indicator light. Field thermostat wiring connects to color-coded wire leads using twist-on wire connections. Cooling controls use contactor and relays for simple application and troubleshooting. MATE-N-LOK plug connectors are used. The electrical control box is not located in the compressor compartment. The controls are mounted to allow removal of the separate access panel for troubleshooting and maintenance without affecting the normal system operating pressures. All wiring internal to the unit is numbered and color-coded.
- **Protected compressor** - The compressor is internally protected against high pressure and temperature. This is done by the simultaneous operation of scroll bypass and a temperature thermal overload sensor, which protects the compressor if undesirable operating conditions occur.
- **Pressure switches** - A high-pressure switch is standard in all units. When abnormal conditions are sensed through the pressure switch, the unit locks out, preventing any further operation until it is reset or the problem is corrected.
- **Exclusive coil design** - The grooved copper tubes and enhanced aluminum fin construction of the outdoor coils improve heat transfer for maximum efficiency and durability. Indoor tube and fin coils have all aluminum construction for reliability and efficient heat transfer.
- **Electric heat** - All electric heat models use 6HK electric heat kits, which are available in 460-3-60 from 10 kW to 25 kW.
- **Easy service access** - Individual access panels provide access to all major components, for example, compressors, indoor coils, blowers, controls, electric heat kits, and filters, making servicing easy. Removing these panels allows easy removal of components such as the blower assembly for maintenance and troubleshooting.
- **Replacement parts** - The installer requires no special training to replace any of the components of these units. The number of new components has been reduced to minimize the inventory of unique parts.
- **Controls** - Demand defrost curves are preloaded into the defrost control for optimized performance based on unit capacities.
- **Filter frame kit** - All three-phase units include a filter frame kit that is shipped inside the unit from production. Field installation is required.
- **Filters** - All three-phase units include an applicable number of 1 in. washable filters, which are shipped inside the unit from production. Field installation is required. Two filters are required for A base units. Three filters are required for B base units.

Nomenclature

Model family	PHE	PHE = packaged heat pump with electric heat
		PCG = packaged AC with gas heat
		PHG = packaged heat pump with gas heat
		PCE = packaged AC with electric heat
Nominal cooling efficiency	4	4 = standard efficiency
		6 = high efficiency
Cabinet size	B	A = small, 35.75 in. x 51.25 in.
		B = large, 45.75 in. x 51.25 in.
Nominal air conditioning cooling capacity Btu/h x 1000	36	36 = 36,000 Btu/h
		48 = 48,000 Btu/h
		60 = 60,000 Btu/h
Gas heating input Btu/h x 1000		050 = 50,000 Btu/h input
		065 = 65,000 Btu/h input
		075 = 75,000 Btu/h input
		100 = 100,000 Btu/h input
		125 = 125,000 Btu/h input
		blank = electric heat
Voltage-phase-frequency	4	2 = 208/230-1-60
		3 = 208/230-3-60
		4 = 460-3-60
NOx approval		X = Low NOx
		blank = not Low NOx
Generation level	4	1 = first generation
		2 = second generation
		3 = third generation
		4 = fourth generation
Revision level	A	A = original release
		B = second release

Nomenclature example: PHE4B3644A is a packaged heat pump with electric heat, standard efficiency, large cabinet, 3 ton, 460 V, three-phase model, fourth generation, original release.

Component location

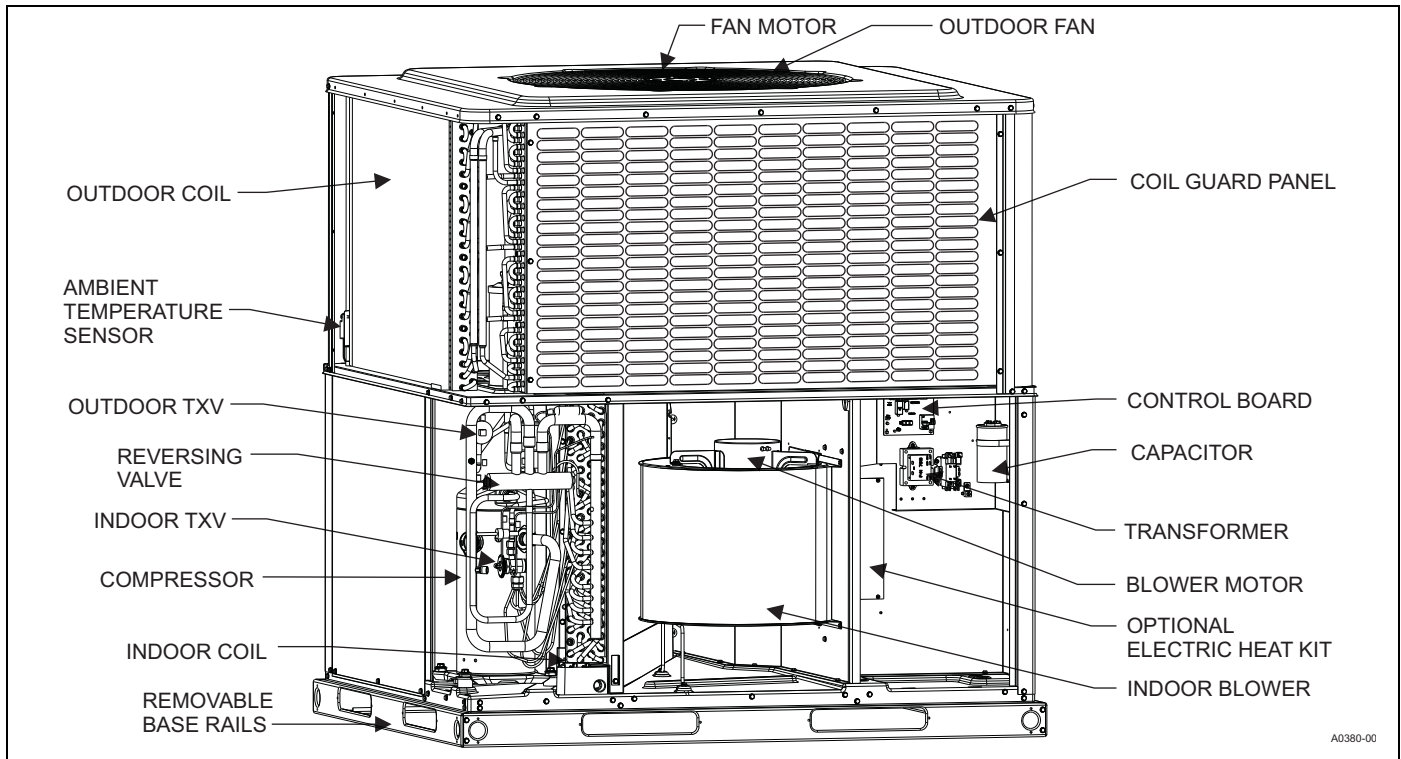

Unit limitations

Model	Voltage-phase-frequency	Unit limitations		
		Applied voltage (V)		Outdoor DB temperature (°F)
		Minimum	Maximum	Maximum
PHE4B3644	460-3-60	432	504	125
PHE4B4844				
PHE4B6044				

Applications and accessories

Packaged equipment series	Application limitations							
	Air temperature at outdoor coil (°F)				Air temperature at indoor coil (°F)			
	Minimum		Maximum		Minimum		Maximum	
	DB cool	DB heat	DB cool	DB heat	WB cool	DB heat	WB cool	DB heat
PHE4*	55	-10	125	75	57	50	72	80

Note: *PHE4A24 models are restricted to operation of 0°F outdoor air temperature.

- **Anchor bracket kit (S1-1HK0601)** - The kit firmly anchors PCG, PCE, PHE, and PHG packaged units to a pad or support structure. When correctly installed, the kit is approved for ground-mounted or roof-mounted applications, wind load certified, and listed with the State of Florida. See <https://floridabuilding.org> for this listing.
- **Economizer for downflow applications (S1-2EE04710024, S1-2EE04710124)** - The modulating integrated economizer provides simultaneous operation between mechanical cooling and economizer operation. The independent blade design ensures proper control and less than 1% leak rate. The economizer includes a hood and mesh bird screen filter integrated into the hood, a dry bulb sensor, and a barometric relief damper. Separate field accessories of single or dual enthalpy kits are also available.
- **Economizer for horizontal applications (S1-2EE04710224, S1-2EE04710324)** - The modulating integrated economizer provides simultaneous operation between the mechanical cooling and economizer operation. The independent blade design ensures proper control and less than 1% leak rate. The economizer includes a hood and mesh bird screen filter integrated into the hood and a dry bulb sensor. Separate field accessories of single enthalpy and dual enthalpy are available.
- **Barometric relief hood (S1-1RD0501)** - Used in conjunction with a horizontal economizer, the barometric relief hood helps to equalize the building pressure caused by the fresh air introduced through the economizer fresh air hood.
- **Single/dual enthalpy sensor (S1-HE-69630NS-2D)** - The sensor replaces the supply air temperature dry bulb sensor standard in the economizer kit. The sensor provides improved economizer operation by sensing the dry bulb temperature of indoor supply air plus the enthalpy content of the outdoor air.
- **Duct/unit mount CO₂ kit (S1-2AQ04700924)** - The sensor kit detects CO₂ levels automatically and overrides the economizer when CO₂ levels rise above the preset limits.
- **Wall mount CO₂ kit (S1-2AQ04701024)** - The sensor kit detects CO₂ levels automatically and overrides the economizer when CO₂ levels rise above the preset limits.
- **Supply air temperature sensor kit (S1-TE-63616E-2D)** - The outdoor supply air temperature sensor kit is used with economizers.
- **Filter frame kit (kit provided) (S1-1FF0602, S1-1FF0601)** - The kit contains the necessary hardware to field install return air filters into the base unit. The filter rack is suitable for 1 in. filters or 2 in. filters.
- **Filter (S1-02647812000)** - Washable 1 in. filter. Two filters are required for A base units. Three filters are required for B base units.
- **Rectangle to round (horizontal) adapter (S1-1AK0110, S1-1AK0111)** - The kit includes one supply and one return air rectangle to round duct adapter. Adapters are preformed and designed to fit over current horizontal duct openings on the base unit. The transition is from rectangle to 12 in. round for the 1AK0110 kit and from rectangle to 14 in. round for the 1AK0111 kit.
- **Rectangle to round (downflow) adapter (S1-1AK0108, S1-1AK0109)** - The kit includes one supply and one return air rectangle to round duct adapter. Adapters are preformed and designed to fit into current downflow duct openings on the roof curb. The transition is from rectangle to 16 in. round for the 1AK0108 kit and from rectangle to 18 in. round for the 1AK0109 kit.
- **Roof curbs (S1-1RC0503, S1-1RC0501)** - NRCA approved curbs provide correct fit to base unit for rooftop installations. Curbs are designed to be assembled through hinge pins in each corner. The kit also provides seal strip to ensure an airtight seal. These are 8 in. high roof curbs.
- **Roof curbs (S1-1RC0504, S1-1RC0502)** - NRCA approved curbs provide correct fit to base unit for rooftop installations. Curbs are designed for assembly through hinge pins in each corner. The kit also provides seal strip to ensure an airtight seal. These are 14 in. high roof curbs.
- **Manual outdoor damper (S1-1FA0502, S1-1FA0501)** - The damper provides 0% to 50% outdoor air capability (field adjustable) and is designed for duct mounted side supply and return applications and unit mounted down supply and return applications. The damper includes hood and screen assembly.
- **Low ambient kit (S1-2LA04701024)** - The kit provides the necessary hardware to convert the unit to operate in cooling cycle down to 0°F. Standard unit operation is 55°F.
- **Base rail hole cover kit (S1-1HC0101)** - The kit provides the necessary hardware to close off openings in the base rails to block off openings and prevent animal entrance.
- **Transition curb kits (S1-1TC01*)** - These adapter kits allow field use of existing installed roof curbs, matching the PHE4 footprint to Affinity roof curbs or Carrier, Trane, or Goodman roof curbs. Curb adapters are optional for current generation Carrier replacements, but are recommended for previous generation applications. Refer to the PHE4 *Price Pages* for more details.
- **Single-point wiring kits (S1-2SPWK031 to 038)** - The kit provides terminal block, fuse blocks, and wiring to allow units with electric heat to be connected to a single source of incoming power.
- **Thermostat** - Compatible thermostat controls are available through accessory sourcing. For optimum performance, these outdoor units are fully compatible with our residential Hx™ Touch Screen Thermostat available through Source 1. For more information, refer to the *Thermostats & Controllers* section at www.simplygettingthejobdone.com.
- **Wall thermostat** - The units are designed to operate with standard, 24 V electronic non power-stealing and electromechanical thermostats. All units can operate with single-stage heat/single-stage cool thermostats - with or without the economizer.

* For additional kit numbers, refer to the *Price Pages*.

Guide specifications

General

Units shall be assembled at a facility with an ISO 9001:2015-certified Quality Management System. These heat pumps are designed for outdoor installation. Only utility and duct connections are required at the point of installation. Heat pumps provide electric cooling and electric heating, with field-installed electric heat kits from 10 kW to 25 kW for backup supplemental heating operation.

Description

Units shall be factory-assembled, single packaged, heat pumps with electric cooling or electric heating units, designed for outdoor installation. They shall have built-in, equal size, field-convertible duct connections for downflow supply and return or horizontal supply and return. The units shall be factory wired, piped, charged with R-410A refrigerant, and factory tested before shipment. All models shall be rated in accordance with DOE and AHRI test procedures for both heating and cooling operation. Units shall be CSA listed to the UL 1995/CAN/CSA No. 236-M90 standards.

- **Operating efficiency** - All heat pump models shall be rated at a minimum of 14.0 SEER (13.4 SEER2) and 8.0 HSPF (6.7 HSPF2) for cooling and heating operation.
- **Low operating sound level** - The upward airflow shall carry the normal operating noise up and away from the living area. The rigid top panel effectively isolates noise. The isolator mounted compressor and the rippled fins of the outdoor coil muffle the normal fan motor and compressor operating sounds. The unique formed base pan also aids in sound attenuation with its structural design. Sound ratings as tested under AHRI test procedures shall be less than 77 dB(A) for all models.

Unit cabinet

The unit cabinet shall be a single-piece design, with drip edges and no-seam corners to provide optimum water integrity. The unit shall have a rigidly mounted outdoor coil guard to provide protection from objects and personnel after installation. The indoor blower section shall be insulated with foil-faced or foam insulation, fastened to prevent insulation from entering the air stream. Cabinet panels shall be separate and easily removable for servicing and maintenance. The unit shall be built on a formed, design base pan, with embossments at critical points to add strength and rigidity and aid in minimizing sound. Full perimeter base rails shall be provided to ensure reliable transit of equipment and facilitate overhead rigging, allowing fork truck access and proper sealing on roof curb applications. Base rails shall be easily removable if their removal is required to lower the unit height. Filters shall be field installed, furnished, and accessible through a removable access door, sealed airtight. The unit's vertical discharge and return duct configuration shall be designed to fit between standard 24 in. O.C. beams without modification to building structure, duct work, and base unit.

- **On-site flexibility** - All model sizes shall use a compact design cabinet in one of two footprints. This provides installer flexibility for placing the correct capacity unit on curbs or pads with the smallest footprint after the internal load has been determined. Field-convertible duct connections from side shot to down shot allow the installer to have greater flexibility with less inventory.

- **Durable finish** - The cabinet shall be made of G90 galvanized steel with a powder paint coating for appearance and protection. The pretreated galvanized steel shall provide a better paint-to-steel bond, which resists corrosion and rust creep. The powder paint finish ensures less fading when exposed to sunlight, and provides superior corrosion resistance. The powder paint finish is 1,000 h salt spray tested.
- **Attractive appearance** - A single-piece top cover containing a top-discharge outdoor fan arrangement shall be used. This requires less square footage on installation and provides a wider variety of installations. The one-piece design adds greater water integrity. Rounded corners with water drip edges add to the attractive appearance and prevent water penetration.
- **Convertible airflow design** - The bottom duct openings shall be covered when they leave the factory, ready to be used for a side supply and side return application. If a bottom supply and bottom return application is required, remove the two panels from the bottom of the unit and place them in the side supply and side return duct openings. No panel cutting is required and no accessory panel is necessary. The convertible airflow design allows for maximum field flexibility and minimum inventory.
- **Utility connections made easy** - Electric utility access shall be provided through the bottom or side of the unit. Utility connections should be made quickly and with a minimum amount of field labor. A field-supplied and field-installed electrical disconnect switch must be installed.
- **Easy service access** - Individual access panels shall provide access to all major components, for example, compressors, indoor coils, blowers, controls, electric heat kits, and filters, making servicing easy. Removing these panels allows easy removal of components such as the blower assembly for maintenance and troubleshooting.
- **Top discharge** - The top-discharge outdoor fan shall not disrupt neighboring areas or dry out vegetation surrounding the unit. The warm air from the top mounted fan is blown up and away from the structure and any landscaping.
- **Outdoor coil grille** - All models shall use a stamped slotted design that provides superior impact protection against small objects during transit and after installation.
- **Indoor blower assembly** - The blower shall be a direct drive design. The blower wheel shall be a double-inlet type with forward-curved blades, dynamically balanced to operate smoothly throughout the entire range of operation. The design shall use constant torque motors. Bearings shall be sealed and permanently lubricated for longer life and no maintenance. The blower assembly shall be a slide-out design for easy removal and cleaning. Indoor blower motors shall be equipped with a standard high-efficiency brushless DC motor (constant torque), also known as a standard ECM motor.
- **Outdoor fan assembly** - The outdoor fan shall be of the direct-driven propeller type, discharge air vertically, have aluminum blades riveted to a corrosion resistant steel spider bracket, and be statically balanced for smooth operation. The outdoor fan motor shall be totally enclosed with permanently lubricated bearings and internally protected against overload conditions.

Refrigerant components

- **Protected compressor** - The compressor shall be a fully hermetic type, direct drive compressor, that is internally protected against high pressure and temperature. This is done by the simultaneous operation of a scroll bypass valve and a temperature thermal overload sensor, which protects the compressor if undesirable operating conditions occur. The hermetic motor shall be suction gas cooled and have a voltage range of +/- 10% of the unit nameplate voltage. Compressors shall have internal isolation and sound muffling to minimize vibration and noise, and be externally isolated on a dedicated, independent mounting.
- **Indoor coils** - Indoor coils shall be of the direct expansion, draw through design and have aluminum plate fins mechanically bonded to seamless internally enhanced aluminum tubes with all joints brazed.
- **Condensate pan** - A corrosion-resistant, long-lasting, water-tight pan shall be positioned below the indoor coil to collect and drain all condensate, preventing build-up of stagnant condensate. The condensate pan conforms to ASHRAE 62-19 standards (Ventilation for Acceptable Indoor Air Quality).
- **Condensate drain** - The 3/4 in. NPT female connection shall be rigidly mounted to ensure correct fit and leak-tight seal.
- **Outdoor coils** - Outdoor coils shall have aluminum plate fins mechanically bonded to seamless internally enhanced copper tubes with all joints brazed, and be a draw through design.
- **Refrigerant circuit and refrigerant safety components shall include the following:** thermal expansion valve (TXV) that is factory mounted and provided, filter drier and strainer to eliminate any foreign matter, and reversing valves to control refrigerant flow.

Controls

- **Simple control circuit** - A printed circuit board shall contain a status or diagnostic indicator light. Field thermostat wiring shall connect to color-coded leads using twist-on wire connections. Cooling controls shall use contactor and relays for simple application and troubleshooting. MATE-N-LOK plug connectors shall be used. The electrical control box shall not be located in the compressor compartment. The controls shall be mounted to allow removal of the separate access panel for troubleshooting and maintenance without affecting the normal system operating pressures. All wiring internal to the unit shall be numbered and color-coded.
- **Controls** - Demand defrost curves shall be preloaded into the defrost control for optimized performance based on unit capacities.
- **Pressure switches** - A high-pressure switch shall be standard in all units. When abnormal conditions are sensed through the pressure switch, the unit locks out, preventing any further operation until it is reset or the problem is corrected.
- **Factory testing** - Installation time and costs shall be reduced by easy power and control wiring connections. All units shall be completely wired, charged with R-410A refrigerant, and tested before shipment. Test stations using a state-of-the-art computerized process system shall be used to ensure product quality. Refrigerant charge and component part numbers are verified using computer bar code scans during assembly. Vital run test statistics such as system pressure, motor currents, air velocity and temperature, unit vibration, and gas system safeties are monitored and recorded by the system to ensure unit performance. This data could be provided by serial number tracking if necessary.
- **Electric heat** - All electric heat models shall use 6HK electric heat kits, which are available in 460-3-60 from 10 kW to 25 kW.

Physical data

Models		PHE4B3644	PHE4B4844	PHE4B6044
Nominal tonnage		3.0	4.0	5.0
AHRI cooling performance	Gross capacity at AHRI A point (MBH)	36.3	49.1	61.3
	AHRI net capacity (MBH)	35.8	48.0	59.5
	EER	11.6	11.6	11.6
	EER2	11.0	11.0	11.0
	SEER	14.0	14.0	14.0
	SEER2	13.4	13.4	13.4
	Nominal CFM	1150	1500	1850
	System power (kW)	2.73	3.79	4.73
	Refrigerant type	R-410A	R-410A	R-410A
Refrigerant charge (lb-oz)	9-6	14-4	11-10	
AHRI heating performance	47°F capacity rating (MBH)	34.8	46.5	56.5
	System power (kW/COP)	3.6	3.7	3.6
	17°F capacity rating (MBH)	19.8	27.0	33.0
	HSPF (Btu/Wh)	8.0	8.0	8.0
	HSPF2 (Btu/Wh)	6.7	6.7	6.7
Dimensions	Length (in.)	51 1/4	51 1/4	51 1/4
	Width (in.)	45 3/4	45 3/4	45 3/4
	Height (in.)	47	53	55
Operating weight (lb)		420	479	485
Compressor type		Scroll	Scroll	Scroll
Outdoor coil data	Face area (sq ft)	17.6	24.2	26.4
	Rows	2	2	2
	Fins per inch	22	22	22
	Tube diameter (mm)	7	7	7
	Circuitry type	Interlaced	Interlaced	Interlaced
	Refrigerant control	TXV	TXV	TXV
Indoor coil data	Face area (sq ft)	6.3	6.3	6.3
	Rows	3	4	4
	Fins per inch	16	16	16
	Tube diameter (in.)	3/8	3/8	3/8
	Circuitry type	Interlaced	Interlaced	Interlaced
	Refrigerant control	TXV	TXV	TXV
Outdoor fan data	Fan diameter (in.)	26	26	26
	Type	Prop	Prop	Prop
	Drive type	Direct	Direct	Direct
	Number of speeds	1	1	1
	Motor (hp)	1/3	1/3	1/3
	RPM	850	850	850
	Nominal total CFM	3450	4000	4000
Direct drive indoor blower data	Fan size (in.)	11 x 10	11 x 10	11 x 10
	Type	Centrifugal	Centrifugal	Centrifugal
	Motor (hp)	1/2	3/4	1
	RPM (maximum)	1200	1200	1200
	Frame size (in.)	48	48	48
Filter size		B	B	B

Note: Field-supplied external filters must be sized so as not to exceed 300 FPM air velocity through disposable filters. All three-phase models include an internal filter rack kit and washable filters. Refer to the instructions supplied with the kit for replacement filter sizes. Filter sizes: B = 20 in. x 30 in.

Cooling performance data - 3 ton																
Packaged unit model number		PHE4B3644														
Condenser entering air temp DB/WB (°F)	ID SCFM	1000					1200					1400				
	IDDB (°F)	80	80	75	80	80	80	80	75	80	80	80	80	75	80	80
	IDWB (°F)	57	62	62	67	72	57	62	62	67	72	57	62	62	67	72
55 / 45	Total capacity (MBH)	38.8	41.2	39.8	45.3	48.0	42.0	43.4	42.0	47.1	49.8	45.2	45.6	44.2	49.0	51.7
	Sensible capacity (MBH)	37.2	34.3	28.1	28.8	22.5	40.3	38.3	31.3	31.1	24.4	43.4	42.2	34.5	33.4	26.3
	Total power (kW)	1.80	1.80	1.81	1.79	1.78	1.86	1.87	1.87	1.85	1.84	1.92	1.93	1.93	1.91	1.91
65 / 55	Total capacity (MBH)	36.3	38.4	37.8	42.4	45.9	39.4	40.5	40.2	44.1	48.3	42.5	42.7	42.6	45.9	50.7
	Sensible capacity (MBH)	34.9	32.8	27.4	27.7	22.6	37.9	36.4	30.6	30.3	24.4	41.0	40.1	33.7	32.9	26.3
	Total power (kW)	2.00	2.00	2.01	1.99	1.98	2.06	2.06	2.07	2.05	2.04	2.13	2.13	2.13	2.11	2.11
75 / 63	Total capacity (MBH)	33.8	35.6	35.8	39.5	43.8	36.8	37.6	38.5	41.1	46.7	39.7	39.7	41.1	42.8	49.7
	Sensible capacity (MBH)	32.6	31.2	26.7	26.6	22.6	35.5	34.6	29.8	29.5	24.5	38.5	38.0	33.0	32.4	26.3
	Total power (kW)	2.21	2.20	2.21	2.20	2.18	2.27	2.26	2.27	2.26	2.24	2.33	2.32	2.34	2.32	2.31
85 / 69	Total capacity (MBH)	32.7	33.7	33.2	37.3	41.6	35.2	35.5	36.6	38.8	44.0	37.8	37.3	40.0	40.4	46.3
	Sensible capacity (MBH)	31.7	30.5	25.3	25.6	21.2	34.4	33.4	28.3	28.6	23.0	37.0	36.4	31.3	31.5	24.8
	Total power (kW)	2.44	2.44	2.44	2.44	2.43	2.51	2.51	2.51	2.50	2.50	2.57	2.57	2.58	2.56	2.56
95 / 75	Total capacity (MBH)	31.5	31.9	30.6	35.0	39.5	33.7	33.4	34.7	36.5	41.2	35.8	34.9	38.9	38.0	43.0
	Sensible capacity (MBH)	30.9	29.8	23.9	24.7	19.7	33.2	32.3	26.8	27.7	21.5	35.6	34.9	29.6	30.7	23.4
	Total power (kW)	2.68	2.68	2.68	2.68	2.68	2.75	2.75	2.75	2.74	2.75	2.82	2.82	2.82	2.81	2.81
105 / 83	Total capacity (MBH)	28.5	28.6	27.1	31.5	35.6	30.2	29.9	29.8	32.5	36.6	31.8	31.2	32.6	33.4	37.6
	Sensible capacity (MBH)	28.1	27.2	22.3	23.2	18.2	29.9	29.2	24.3	25.9	19.6	31.7	31.2	26.4	28.6	21.1
	Total power (kW)	2.99	2.99	2.99	2.99	3.00	3.06	3.06	3.06	3.06	3.07	3.13	3.13	3.13	3.13	3.14
115 / 89	Total capacity (MBH)	25.6	25.4	23.7	28.1	31.9	26.8	26.5	25.1	28.6	32.2	28.0	27.6	26.5	29.0	32.4
	Sensible capacity (MBH)	25.4	24.7	20.6	21.7	16.7	26.7	26.2	22.0	24.1	17.8	27.9	27.6	23.4	26.6	18.9
	Total power (kW)	3.29	3.29	3.29	3.30	3.31	3.36	3.36	3.36	3.37	3.38	3.43	3.44	3.43	3.44	3.45
125 / 95	Total capacity (MBH)	22.7	22.2	20.3	24.6	28.2	23.4	23.1	20.3	24.6	27.7	24.1	24.0	20.3	24.6	27.3
	Sensible capacity (MBH)	22.7	22.2	19.0	20.2	15.3	23.4	23.1	19.7	22.4	16.0	24.1	24.0	20.3	24.6	16.7
	Total power (kW)	3.59	3.59	3.59	3.61	3.62	3.66	3.67	3.66	3.68	3.69	3.74	3.74	3.73	3.75	3.76

Cooling performance data - 4 ton																
Packaged unit model number		PHE4B4844														
Condenser entering air temp DB/WB (°F)	ID SCFM	1300					1500					1700				
	IDDB (°F)	80	80	75	80	80	80	80	75	80	80	80	80	75	80	80
	IDWB (°F)	57	62	62	67	72	57	62	62	67	72	57	62	62	67	72
55 / 45	Total capacity (MBH)	49.8	53.9	53.6	58.9	60.3	52.3	55.4	55.0	59.6	60.7	54.9	56.8	56.5	60.3	61.0
	Sensible capacity (MBH)	49.4	45.8	39.1	39.5	36.7	52.3	48.7	41.7	42.1	39.6	54.9	51.7	44.3	44.6	42.5
	Total power (kW)	2.48	2.45	2.45	2.43	2.42	2.53	2.51	2.51	2.49	2.49	2.58	2.57	2.57	2.55	2.55
65 / 55	Total capacity (MBH)	47.8	50.7	50.8	56.4	58.1	50.4	52.2	52.3	57.3	59.0	52.9	53.8	53.7	58.3	59.9
	Sensible capacity (MBH)	47.8	43.7	37.4	38.0	35.0	50.4	46.6	39.9	40.8	37.3	52.9	49.5	42.4	43.6	39.6
	Total power (kW)	2.74	2.73	2.73	2.72	2.72	2.80	2.79	2.80	2.79	2.78	2.86	2.86	2.86	2.85	2.85
75 / 63	Total capacity (MBH)	45.9	47.5	48.1	53.9	56.0	48.4	49.1	49.5	55.1	57.3	51.0	50.8	51.0	56.3	58.7
	Sensible capacity (MBH)	45.9	41.6	35.7	36.6	33.2	48.4	44.5	38.1	39.5	35.0	51.0	47.3	40.6	42.5	36.7
	Total power (kW)	3.00	3.01	3.01	3.01	3.01	3.07	3.08	3.08	3.08	3.08	3.14	3.15	3.15	3.15	3.15
85 / 69	Total capacity (MBH)	43.4	44.6	45.1	50.6	53.5	45.2	45.9	46.4	51.9	54.6	46.9	47.2	47.6	53.1	55.8
	Sensible capacity (MBH)	43.4	40.3	34.0	35.1	32.6	45.2	43.0	36.4	37.7	34.4	46.9	45.6	38.8	40.4	36.1
	Total power (kW)	3.31	3.31	3.32	3.34	3.11	3.23	3.38	3.39	3.41	3.15	3.16	3.46	3.47	3.48	3.19
95 / 75	Total capacity (MBH)	40.9	41.8	42.2	47.3	51.0	41.9	42.7	43.3	48.6	51.9	42.8	43.6	44.3	49.9	52.9
	Sensible capacity (MBH)	40.9	39.0	32.4	33.6	32.0	41.9	41.5	34.7	36.0	33.8	42.8	43.6	37.0	38.3	35.5
	Total power (kW)	3.61	3.62	3.64	3.66	3.21	3.39	3.69	3.71	3.73	3.22	3.18	3.77	3.78	3.81	3.23
105 / 83	Total capacity (MBH)	37.4	38.0	37.4	42.6	46.2	38.0	38.5	38.1	43.6	47.1	38.5	39.0	38.9	44.6	48.1
	Sensible capacity (MBH)	37.4	36.2	30.1	31.2	29.1	38.0	37.8	32.1	33.4	30.8	38.5	39.0	34.1	35.7	32.4
	Total power (kW)	3.87	3.88	4.05	4.07	3.78	3.73	3.93	4.12	4.14	3.81	3.59	3.98	4.20	4.22	3.84
115 / 89	Total capacity (MBH)	34.0	34.3	32.7	38.0	41.5	34.1	34.4	33.1	38.7	42.5	34.3	34.5	33.6	39.4	43.4
	Sensible capacity (MBH)	34.0	33.5	27.9	28.8	26.4	34.1	34.2	29.6	31.0	27.9	34.3	34.5	31.3	33.1	29.4
	Total power (kW)	4.13	4.13	4.44	4.46	4.33	4.06	4.16	4.52	4.54	4.39	3.99	4.19	4.59	4.62	4.44
125 / 95	Total capacity (MBH)	30.6	30.6	28.0	33.5	36.9	30.3	30.3	28.1	33.8	37.8	30.1	30.1	28.3	34.1	38.7
	Sensible capacity (MBH)	30.6	30.6	25.6	26.5	23.6	30.3	30.3	27.1	28.5	25.0	30.1	30.1	28.3	30.5	26.5
	Total power (kW)	4.38	4.38	4.84	4.86	4.88	4.39	4.39	4.92	4.94	4.96	4.39	4.39	4.99	5.01	5.04

Cooling performance data - 5 ton																
Packaged unit model number		PHE4B6044														
Condenser entering air temp DB/WB (°F)	ID SCFM	1600					1800					2000				
	IDDB (°F)	80	80	75	80	80	80	80	75	80	80	80	80	75	80	80
	IDWB (°F)	57	62	62	67	72	57	62	62	67	72	57	62	62	67	72
55 / 45	Total capacity (MBH)	65.6	69.4	68.1	73.1	72.9	69.0	71.4	70.3	74.5	74.5	72.5	73.5	72.5	75.8	76.0
	Sensible capacity (MBH)	64.3	58.0	48.1	47.3	37.1	67.0	62.4	51.6	49.8	41.1	69.7	66.8	55.0	52.3	45.0
	Total power (kW)	3.18	3.16	3.15	3.15	3.13	3.28	3.26	3.24	3.24	3.24	3.37	3.36	3.34	3.34	3.34
65 / 55	Total capacity (MBH)	61.4	64.7	64.3	69.9	72.4	65.0	67.0	66.8	71.5	74.0	68.6	69.2	69.3	73.1	75.6
	Sensible capacity (MBH)	60.1	55.3	46.5	46.0	36.8	63.3	59.9	50.1	49.0	39.5	66.5	64.5	53.7	51.9	42.2
	Total power (kW)	3.51	3.50	3.50	3.51	3.51	3.61	3.60	3.59	3.60	3.61	3.71	3.69	3.69	3.70	3.70
75 / 63	Total capacity (MBH)	57.2	60.1	60.4	66.8	72.0	61.0	62.6	63.3	68.6	73.6	64.7	65.0	66.1	70.4	75.3
	Sensible capacity (MBH)	55.9	52.6	44.8	44.8	36.5	59.6	57.4	48.6	48.2	38.0	63.4	62.2	52.3	51.6	39.5
	Total power (kW)	3.84	3.84	3.85	3.87	3.88	3.95	3.93	3.94	3.97	3.97	4.05	4.03	4.04	4.06	4.07
85 / 69	Total capacity (MBH)	54.8	56.9	56.1	62.3	67.7	58.2	59.1	58.2	64.1	69.1	61.5	61.2	60.4	65.9	70.4
	Sensible capacity (MBH)	54.0	51.4	42.5	42.6	33.5	57.5	55.6	46.1	46.2	35.6	61.0	59.9	49.7	49.7	37.6
	Total power (kW)	4.24	4.24	4.24	4.26	4.29	4.34	4.33	4.33	4.36	4.39	4.45	4.43	4.43	4.46	4.48
95 / 75	Total capacity (MBH)	52.4	53.8	51.7	57.8	63.4	55.4	55.6	53.2	59.6	64.5	58.4	57.4	54.6	61.4	65.6
	Sensible capacity (MBH)	52.2	50.1	40.1	40.4	30.6	55.4	53.9	43.5	44.1	33.2	58.4	57.4	47.0	47.8	35.8
	Total power (kW)	4.63	4.63	4.63	4.66	4.71	4.73	4.73	4.73	4.76	4.80	4.84	4.83	4.83	4.86	4.90
105 / 83	Total capacity (MBH)	48.2	48.8	46.6	52.5	57.4	50.5	50.7	47.8	53.6	58.1	52.9	52.6	49.1	54.8	58.8
	Sensible capacity (MBH)	48.1	46.5	37.6	38.1	28.8	50.5	49.7	40.9	41.6	31.0	52.9	52.6	44.2	45.0	33.3
	Total power (kW)	5.15	5.15	5.14	5.18	5.23	5.26	5.26	5.25	5.28	5.33	5.37	5.36	5.35	5.39	5.42
115 / 89	Total capacity (MBH)	44.1	44.1	41.5	47.3	51.6	45.8	46.0	42.7	47.8	52.0	47.6	47.9	43.8	48.4	52.3
	Sensible capacity (MBH)	44.1	43.0	35.2	35.9	27.0	45.8	45.6	38.3	39.1	28.9	47.6	47.9	41.4	42.3	30.7
	Total power (kW)	5.66	5.65	5.64	5.69	5.74	5.77	5.77	5.75	5.79	5.83	5.88	5.88	5.86	5.89	5.93
125 / 95	Total capacity (MBH)	40.0	39.3	36.5	42.0	45.8	41.2	41.3	37.5	42.0	45.8	42.4	43.3	38.4	42.0	45.7
	Sensible capacity (MBH)	40.0	39.3	32.8	33.7	25.3	41.2	41.3	35.8	36.7	26.8	42.4	43.3	38.4	39.6	28.2
	Total power (kW)	6.17	6.16	6.14	6.20	6.24	6.28	6.28	6.25	6.30	6.34	6.39	6.39	6.37	6.40	6.44

Heating performance data - 3 ton										
Packaged unit model number		PHE4B3644								
Air temperature entering outdoor coil (°F)	Air temperature entering indoor coil (°F)	ID CFM								
		1000			1200			1400		
		MBH	COP	kW	MBH	COP	kW	MBH	COP	kW
60	60	43.0	4.69	2.69	44.6	4.95	2.64	46.1	5.22	2.59
	70	40.2	3.97	2.97	41.9	4.22	2.91	43.7	4.50	2.85
	80	37.3	3.36	3.25	39.3	3.62	3.18	41.3	3.89	3.11
47	60	34.1	3.87	2.58	35.8	4.11	2.55	37.4	4.33	2.53
	70	33.0	3.42	2.83	34.6	3.62	2.80	36.2	3.84	2.76
	80	31.9	3.03	3.09	33.4	3.22	3.04	34.9	3.41	3.00
40	60	30.0	3.49	2.52	31.6	3.69	2.51	33.2	3.91	2.49
	70	29.5	3.13	2.76	30.9	3.31	2.74	32.4	3.49	2.72
	80	29.0	2.83	3.00	30.2	2.98	2.97	31.5	3.14	2.94
30	60	25.0	3.00	2.44	26.4	3.17	2.44	27.8	3.34	2.44
	70	24.8	2.74	2.65	26.0	2.88	2.65	28.0	3.10	2.65
	80	24.7	2.52	2.87	25.6	2.62	2.86	26.0	2.66	2.86
17	60	19.9	2.50	2.33	20.9	2.61	2.35	21.9	2.69	2.38
	70	19.4	2.26	2.52	20.2	2.33	2.54	21.0	2.39	2.57
	80	18.9	2.05	2.70	19.6	2.10	2.73	20.2	2.15	2.75
10	60	17.9	2.31	2.27	18.5	2.35	2.31	19.1	2.39	2.34
	70	16.9	2.03	2.44	17.4	2.06	2.48	18.0	2.09	2.52
	80	15.8	1.77	2.61	16.3	1.80	2.65	16.8	1.83	2.69

Heating performance data - 4 ton										
Packaged unit model number		PHE4B4844								
Air temperature entering outdoor coil (°F)	Air temperature entering indoor coil (°F)	ID CFM								
		1300			1500			1700		
		MBH	COP	kW	MBH	COP	kW	MBH	COP	kW
60	60	59.8	4.77	3.68	60.1	5.02	3.51	60.4	5.30	3.34
	70	57.2	4.07	4.12	57.8	4.30	3.94	58.4	4.55	3.76
	80	54.6	3.50	4.57	55.5	3.72	4.37	56.5	3.96	4.18
47	60	48.6	4.05	3.52	49.2	4.27	3.38	49.8	4.52	3.23
	70	46.4	3.45	3.94	47.0	3.64	3.78	47.6	3.84	3.63
	80	44.2	2.98	4.35	44.8	3.13	4.19	45.4	3.31	4.02
40	60	43.1	3.67	3.44	43.8	3.88	3.31	44.5	4.10	3.18
	70	41.0	3.14	3.83	41.6	3.30	3.70	42.1	3.47	3.56
	80	39.0	2.70	4.23	39.4	2.82	4.09	39.8	2.96	3.94
30	60	35.7	3.16	3.31	36.5	3.34	3.20	37.3	3.54	3.09
	70	33.9	2.69	3.69	34.4	2.82	3.57	34.9	2.96	3.46
	80	32.1	2.32	4.06	32.3	2.40	3.94	32.5	2.49	3.82
17	60	27.2	2.53	3.15	27.9	2.66	3.07	28.6	2.80	2.99
	70	26.8	2.24	3.50	27.4	2.35	3.41	27.8	2.45	3.33
	80	23.8	1.82	3.84	23.9	1.86	3.76	24.0	1.92	3.67
10	60	23.1	2.21	3.07	23.7	2.32	3.00	24.4	2.44	2.93
	70	21.4	1.84	3.40	21.8	1.92	3.33	22.1	1.99	3.26
	80	19.8	1.56	3.72	19.8	1.59	3.66	19.9	1.62	3.59

Heating performance data - 5 ton										
Packaged unit model number		PHE4B6044								
Air temperature entering outdoor coil (°F)	Air temperature entering indoor coil (°F)	ID CFM								
		1600			1800			2000		
		MBH	COP	kW	MBH	COP	kW	MBH	COP	kW
60	60	71.8	4.84	4.35	72.1	4.96	4.26	72.3	5.10	4.16
	70	67.7	4.14	4.79	69.2	4.33	4.69	70.8	4.53	4.58
	80	63.5	3.56	5.23	67.0	3.84	5.12	70.4	4.13	5.00
47	60	56.4	3.96	4.17	57.4	4.09	4.11	58.3	4.22	4.05
	70	55.5	3.54	4.59	56.8	3.68	4.52	58.1	3.83	4.45
	80	54.5	3.19	5.01	56.2	3.34	4.93	57.9	3.50	4.85
40	60	49.8	3.59	4.07	51.0	3.71	4.03	52.2	3.84	3.98
	70	49.6	3.24	4.48	50.9	3.38	4.42	52.2	3.50	4.37
	80	49.3	2.95	4.89	50.7	3.08	4.82	52.1	3.21	4.76
30	60	42.2	3.15	3.93	43.4	3.25	3.91	44.5	3.35	3.89
	70	41.8	2.84	4.32	42.0	2.87	4.29	44.8	3.07	4.27
	80	41.5	2.58	4.71	41.0	2.57	4.68	45.1	2.85	4.64
17	60	35.8	2.80	3.75	36.0	2.81	3.76	36.3	2.82	3.77
	70	33.2	2.36	4.12	34.5	2.45	4.12	37.1	2.63	4.13
	80	30.6	2.00	4.48	34.3	2.24	4.49	37.9	2.47	4.49
10	60	32.3	2.59	3.65	32.4	2.58	3.68	32.6	2.58	3.71
	70	28.5	2.08	4.01	30.9	2.25	4.03	33.4	2.42	4.05
	80	24.7	1.66	4.36	29.4	1.97	4.38	34.1	2.27	4.40

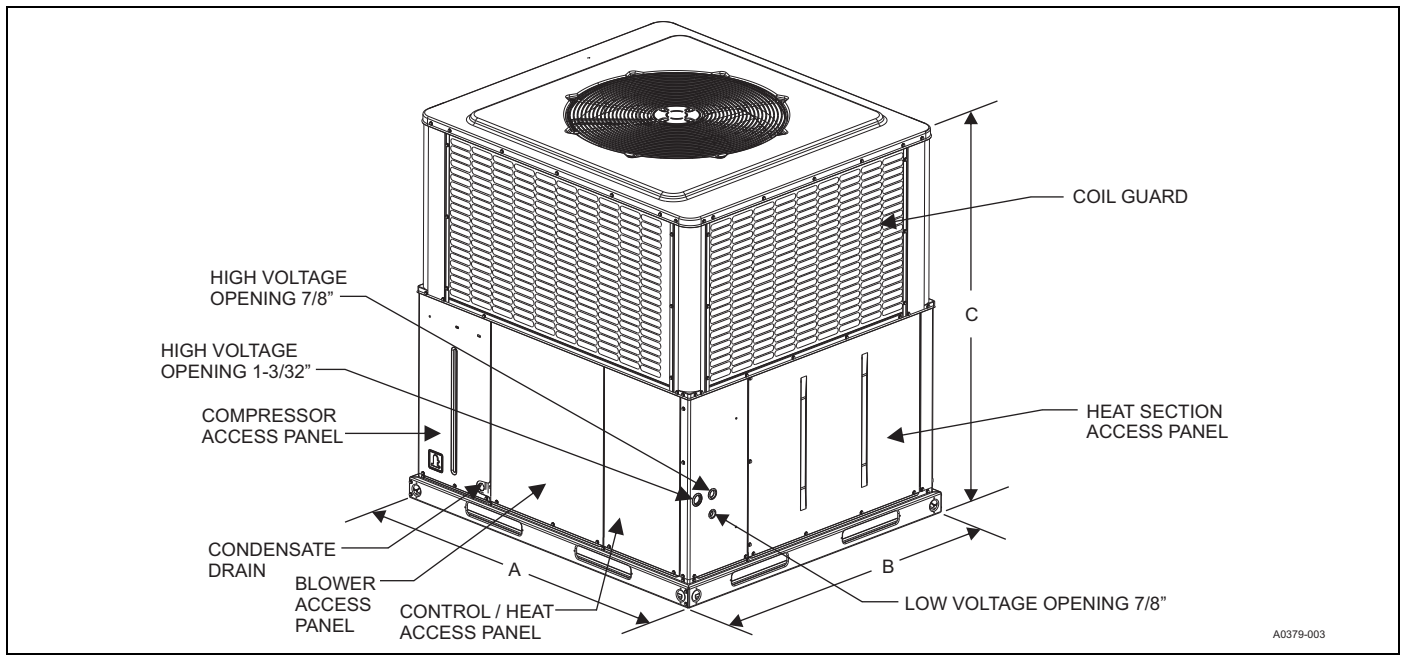

Unit dimensions

Model	Dimensions (in.)		
	A	B	C
PHE4B3644	51 1/4	45 3/4	47
PHE4B4844	51 1/4	45 3/4	53
PHE4B6044	51 1/4	45 3/4	55

Unit clearances

Direction	Distance (in.)	Direction	Distance (in.)
Top ¹	36	Right side	36
Side opposite ducts	36	Left side	24
Duct panel	0	Bottom ^{2,3}	1

1. Provide a minimum clearance of 1 in. on all sides of the supply air duct for the first 3 ft of the duct for 20 kW and 25 kW heaters, 0 in. thereafter. For all other heaters, make sure that there is 0 in. clearance on all sides for the entire length of the supply air duct.
 2. Install units outdoors. Make sure that overhanging structures or shrubs do not obstruct the outdoor air discharge outlet.
 3. You can install units on combustible materials made from wood or class A, B, or C roof covering materials if the factory base rails are left in place as shipped.
- Note:** For units installed on a roof curb, you can reduce the minimum clearance between combustible roof curb material and the supply air duct from 1 in. to 1/2 in.

Electric heat minimum supply air

Model	Voltage-phase-frequency	Minimum blower speed for electric heat			
		Heater (kW)			
		10	15	20	25
PHE4B3644	460-3-60	Medium high (4)	High (5)	--	--
PHE4B4844	460-3-60	Medium low (2)	Medium low (2)	Medium low (2)	--
PHE4B6044	460-3-60	Medium low (2)	Medium low (2)	Medium low (2)	Medium high (4)

Indoor blower specifications

Model	Motor				
	HP	RPM	Efficiency	SF	Frame
PHE4B3644	1/2	Variable	0.8	1.0	48
PHE4B4844	3/4	Variable	0.8	1.0	48
PHE4B6044	1	Variable	0.8	1.0	48

Heat pump - cooling sound performance

Model (ton)	Sound rating ¹ dB(A)	Octave band centerline frequency (Hz)						
		125	250	500	1000	2000	4000	8000
36	72.6	77.9	66.6	64.7	64.4	58.1	54.8	47.4
48	72.4	75.2	66.8	62.9	63.5	58.4	57.3	50.3
60	72.7	73.6	66.2	63.3	63.9	59.6	59.6	52.2

1. Rated in accordance with AHRI Standard 270.

Heat pump - heating sound performance

Model (ton)	Sound rating ¹ dB(A)	Octave band centerline frequency (Hz)						
		125	250	500	1000	2000	4000	8000
36	73.7	78.1	67.2	66.1	65.4	58.3	54.8	48.7
48	73.8	72.4	67.4	63.4	64.8	60.4	59.5	55.2
60	74.1	74.9	66.3	65.1	65.5	59.6	59.5	52.8

1. Rated in accordance with AHRI Standard 270.

Electric heat performance data: 460-3-60

Heater models ¹	Nominal kW at 480 V	Total heat	
		kW	MBH
		460 V	460 V
6HK06501046	9.6	8.8	30.1
6HK06501546	14.4	13.2	45.1
6HK06502046	19.2	17.6	60.2
6HK06502546	24.0	22.0	75.2

1. 6HK0 = no service disconnect.

Electrical data - 460-3-60 - single source power

Model	Compressor			OD fan motor	Blower motor	Electric heat option				MCA ¹	Max fuse ² or breaker ³ size	MCA ¹
	RLA	LRA	MCC	FLA	FLA	Heater kit ⁴	Heater (kW)	Stages	Heater (A)	Total unit (A)	Total unit (A)	Unit minus heater (A)
PHE4B3644	3.8	31	5.9	1.08	1.95	none	--	--	--	7.8	15	7.8
						6HK06501046	8.8	1	11	21.5	25	7.8
						6HK06501546	13.2	1	16.6	28.5	30	7.8
PHE4B4844	6	60	9.4	1.08	3.3	none	--	--	--	11.9	15	11.9
						6HK06501046	8.8	1	11	25.6	30	11.9
						6HK06501546	13.2	1	16.6	32.6	35	11.9
						6HK06502046	17.6	1	22.1	39.5	40	11.9
PHE4B6044	6.3	60	9.8	1.08	3.3	none	--	--	--	12.3	15	12.3
						6HK06501046	8.8	1	11	26	30	12.3
						6HK06501546	13.2	1	16.6	33	35	12.3
						6HK06502046	17.6	1	22.1	39.9	40	12.3
						6HK06502546	22	1	27.6	46.8	50	12.3

1. Minimum circuit ampacity.

2. Maximum overcurrent protection per standard UL 1995.

3. Fuse or HACR circuit breaker is field installed.

4. Single-point connection kit is required.

Note: Single-source power MCA and MOP requirements are given here for reference if the unit is installed with a field-installed single-point power modification.

Single-point wiring kit

Unit model number	Voltage-phase-frequency	Heater kit	Single-point wiring kit
PHE4B36	460-3-60	6HK06501046	S1-2SPWK036
		6HK06501546	S1-2SPWK036
PHE4B48		6HK06501046	S1-2SPWK036
		6HK06501546	S1-2SPWK036
PHE4B60		6HK06502046	S1-2SPWK036
		6HK06501046	S1-2SPWK036
		6HK06501546	S1-2SPWK036
		6HK06502046	S1-2SPWK036
	6HK06502546	S1-2SPWK037	

Note: The 20 kW heater kits and 25 kW heater kits include circuit breakers.

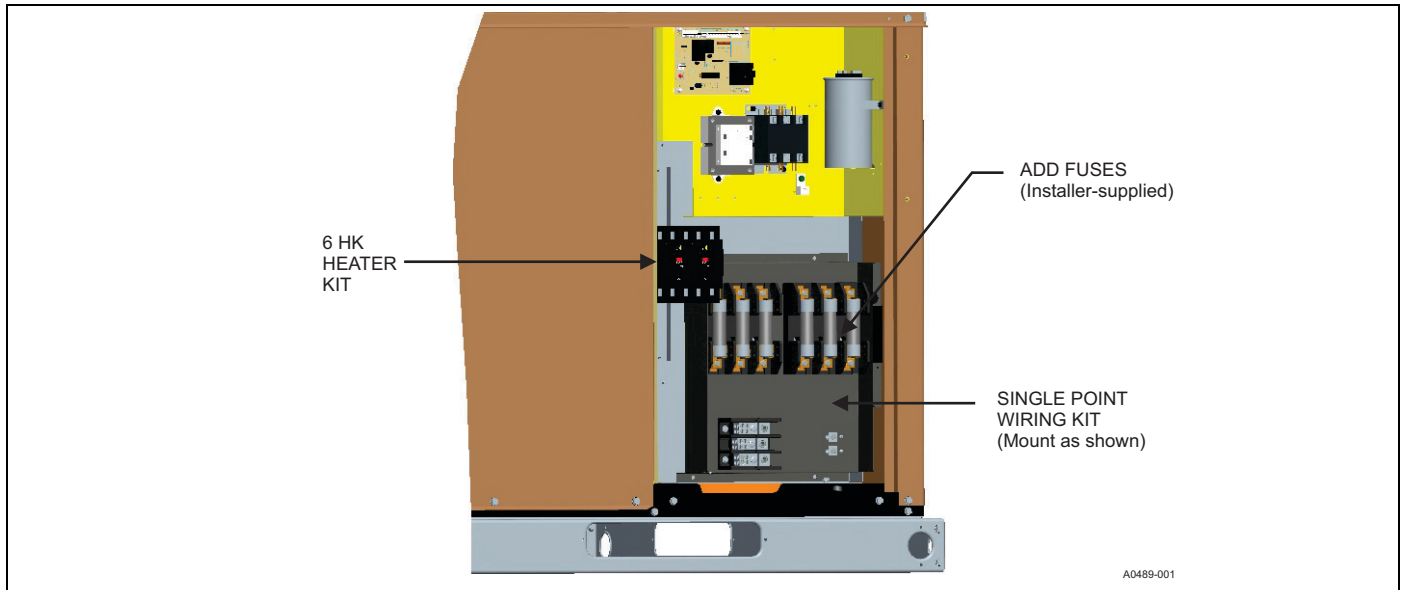

Electrical data - 460-3-60 multi source power

Model	Compressor			OD fan motor FLA	Blower motor FLA	Electric heat option				Circuit 1 Unit minus heaters		Circuit 2 Heaters	
	RLA	LRA	MCC			Heater kit	Heater (kW)	Stages	Heater (A)	MCA ¹ (A)	Max fuse ² or breaker ³ size (A)	MCA ¹ (A)	Max fuse ² or breaker ³ size (A)
PHE4B36	3.8	31	5.9	1.08	1.95	none	--	--	--	7.8	15	--	--
						6HK06501046	8.8	1	11	7.8	15	13.8	15
						6HK06501546	13.2	1	16.6	7.8	15	20.8	25
PHE4B48	6	60	9.4	1.08	3.3	none	--	--	--	11.9	15	--	--
						6HK06501046	8.8	1	11	11.9	15	13.8	15
						6HK06501546	13.2	1	16.6	11.9	15	20.8	25
						6HK06502046	17.6	1	22.1	11.9	15	27.6	30
PHE4B60	6.3	60	9.8	1.08	3.3	none	--	--	--	12.3	15	--	--
						6HK06501046	8.8	1	11	12.3	15	13.8	15
						6HK06501546	13.2	1	16.6	12.3	15	20.8	25
						6HK06502046	17.6	1	22.1	12.3	15	27.6	30
						6HK06502546	22	1	27.6	12.3	15	34.5	35

- 1. Minimum circuit ampacity.
- 2. Maximum overcurrent protection per standard UL 1995.
- 3. Fuse or HACR circuit breaker is field installed.

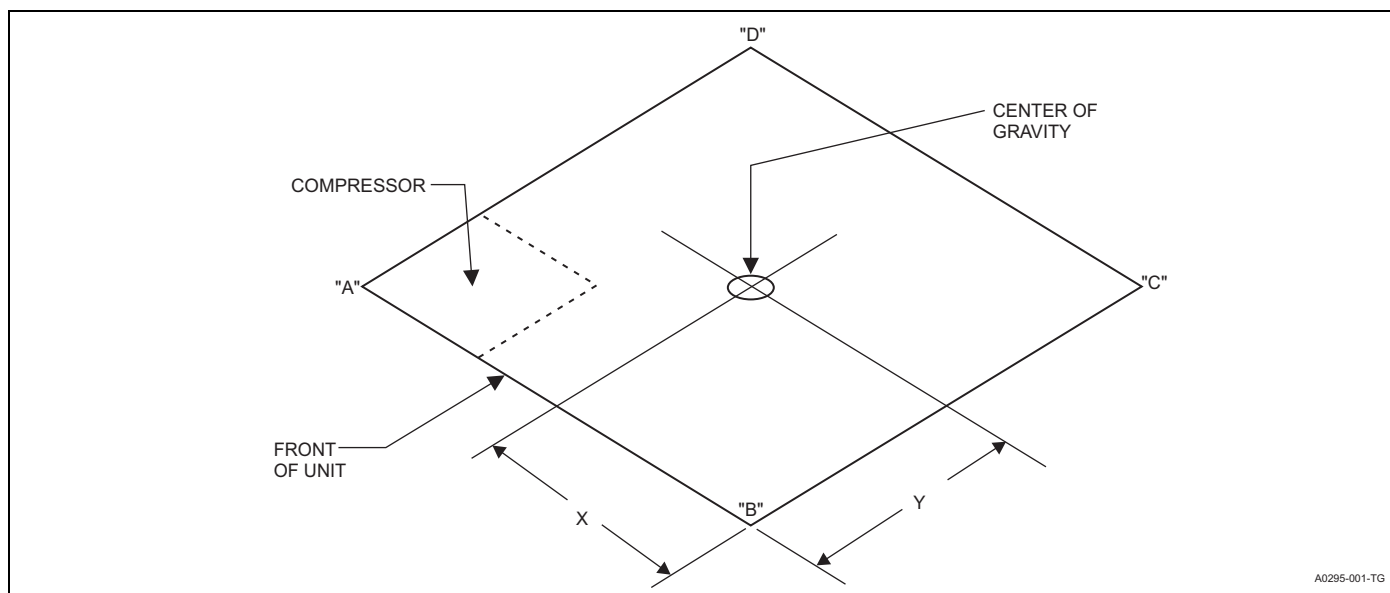

A0295-001-TG

Weights and dimensions

Model	Weight (lb)		Center of gravity (in.)		Four-point load location (lb)			
	Shipping	Operating	X	Y	A	B	C	D
PHE4B3644	425	420	29	18	155	90	91	74
PHE4B4844	484	479	29	19	171	100	100	91
PHE4B6044	490	485	29	19	174	106	102	94

Airflow performance - side duct application

Model	Motor speed	External static pressure (in. W.C.)								
		0.1	0.2	0.3	0.4	0.5	0.6	0.7	0.8	1.0
		SCFM	SCFM	SCFM	SCFM	SCFM	SCFM	SCFM	SCFM	SCFM
PHE4B3644	Low (1)	880	830	770	690	620	550	500	440	200
	Medium low (2)	1180	1130	1090	1040	990	930	860	780	670
	Medium (3)	1310	1270	1230	1190	1140	1100	1040	970	840
	Medium high (4)	1440	1400	1360	1320	1280	1240	1190	1150	1010
	High (5)	1550	1510	1470	1440	1400	1350	1310	1270	1160
PHE4B4844	Low (1)	1190	1130	1080	1030	970	900	840	790	680
	Medium low (2)	1520	1480	1450	1400	1360	1320	1280	1240	1150
	Medium (3)	1620	1580	1550	1510	1470	1430	1390	1350	1270
	Medium high (4)	1730	1690	1660	1620	1580	1540	1500	1470	1390
	High (5)	2010	1980	1950	1910	1870	1840	1800	1760	1680
PHE4B6044	Low (1)	1340	1290	1240	1190	1140	1110	1050	1000	870
	Medium low (2)	1610	1570	1540	1500	1450	1420	1380	1340	1260
	Medium (3)	1900	1870	1840	1800	1760	1730	1690	1650	1580
	Medium high (4)	2020	1990	1960	1920	1880	1850	1810	1770	1700
	High (5)	2250	2210	2190	2160	2120	2080	2050	2000	1970

Notes:

Airflow is tested with dry coil conditions, without air filters, at 460 V.

Applications above 0.8 in. W.C. external static pressure are not recommended.

Brushless DC high-efficiency standard ECM blower motor is used for all indoor blower assemblies.

Heating applications are tested at 0.50 in. W.C. external static pressure. Cooling applications are tested per AHRI Standard 210/240.

The differences between side duct airflows and bottom duct airflows are insignificant.

Additional static resistance

Size (ton)	CFM	Wet indoor coil	Economizer ¹	Filter frame kit
036 (3.0)	700	0.01	0.00	0.04
	800	0.02	0.01	0.06
	900	0.03	0.01	0.08
	1000	0.04	0.01	0.10
	1100	0.05	0.01	0.13
	1200	0.06	0.02	0.16
	1300	0.07	0.03	0.17
	1400	0.08	0.04	0.18
048 (4.0)	1100	0.02	0.02	0.04
	1200	0.03	0.02	0.04
	1300	0.04	0.02	0.05
	1400	0.05	0.03	0.05
	1500	0.06	0.04	0.06
	1600	0.07	0.04	0.07
	1700	0.07	0.04	0.08
	1800	0.08	0.04	0.09
	1900	0.09	0.05	0.10
	2000	0.09	0.05	0.11
060 (5.0)	1100	0.02	0.02	0.04
	1200	0.03	0.02	0.04
	1300	0.04	0.02	0.05
	1400	0.05	0.03	0.05
	1500	0.06	0.04	0.06
	1600	0.07	0.04	0.07
	1700	0.07	0.04	0.08
	1800	0.08	0.04	0.09
	1900	0.09	0.05	0.10
	2000	0.09	0.05	0.11

1. The pressure drop through the economizer is greater for 100% outdoor air than for 100% return air. If the resistance of the return air duct is less than 0.25 IWG, the unit delivers less CFM during full economizer operation.

Note: Filter pressure drop is based on standard filter media tested at velocities not to exceed 300 ft/min.

Bottom duct dimensions (in.)

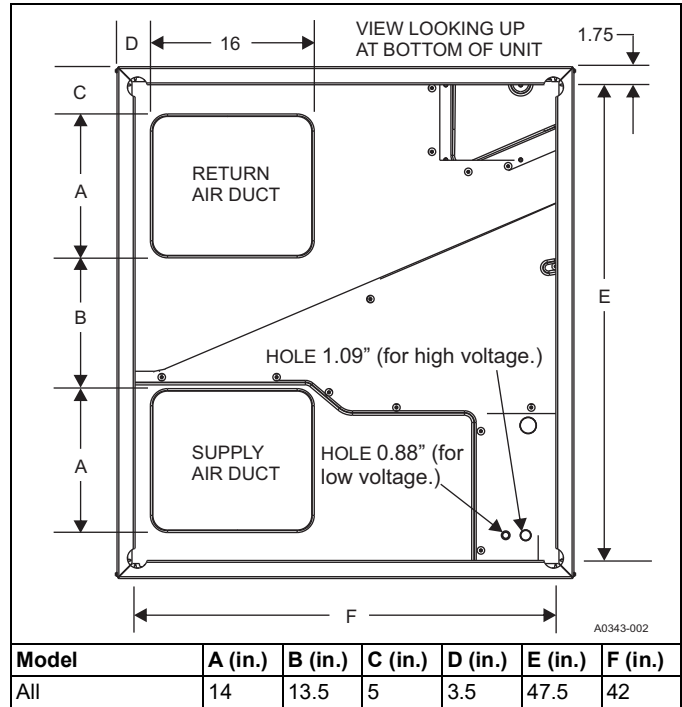

Rear duct dimensions (in.)

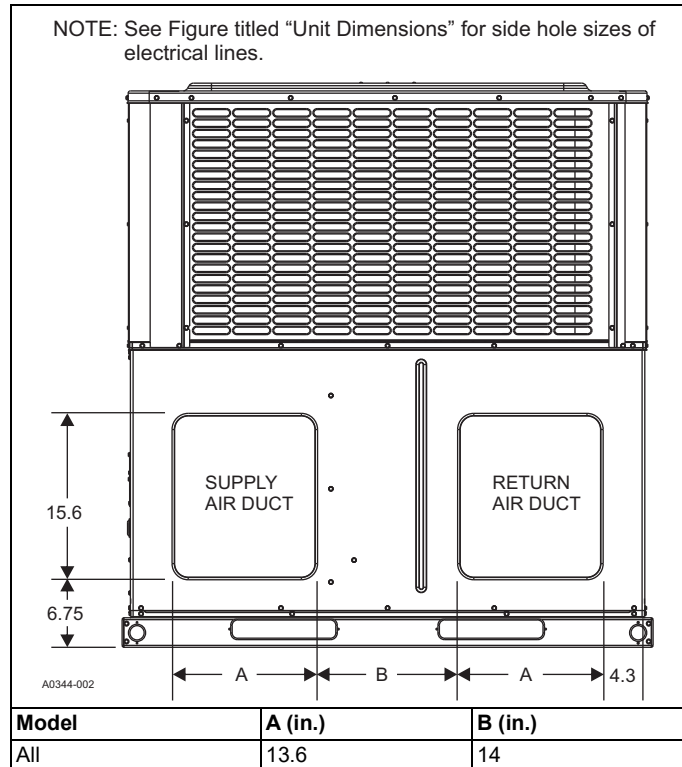

Unit typical duct applications

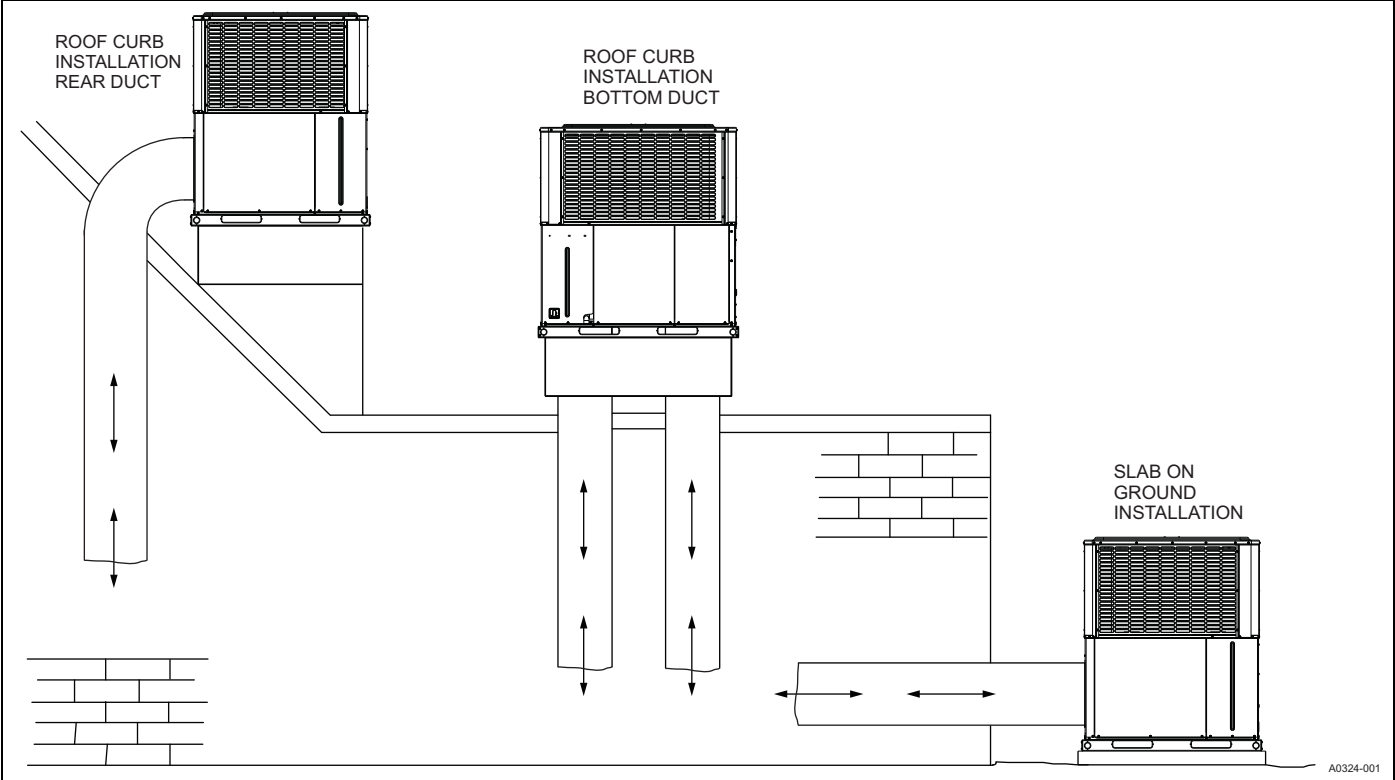

Unit typical slab on ground installation

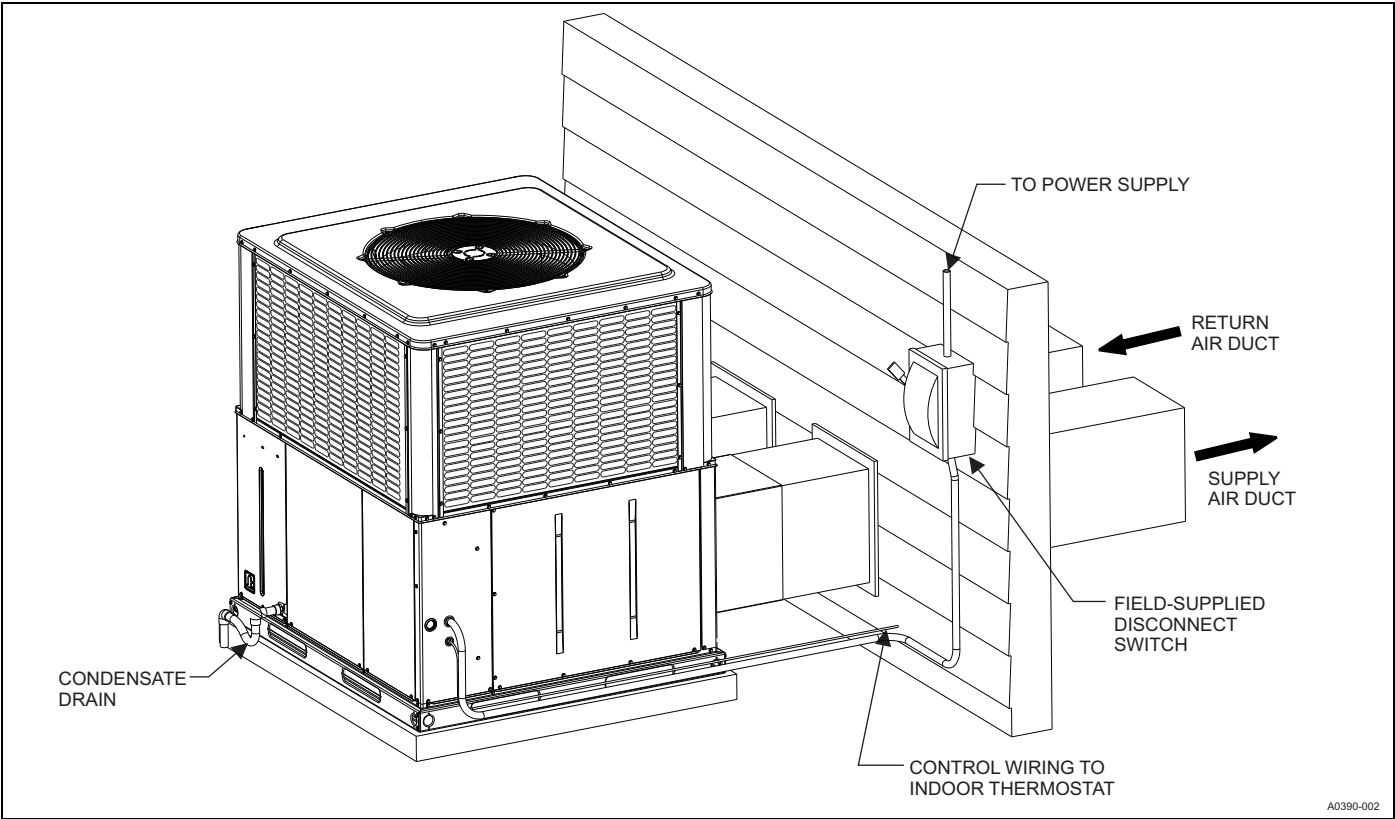

Unit typical roof curb installation

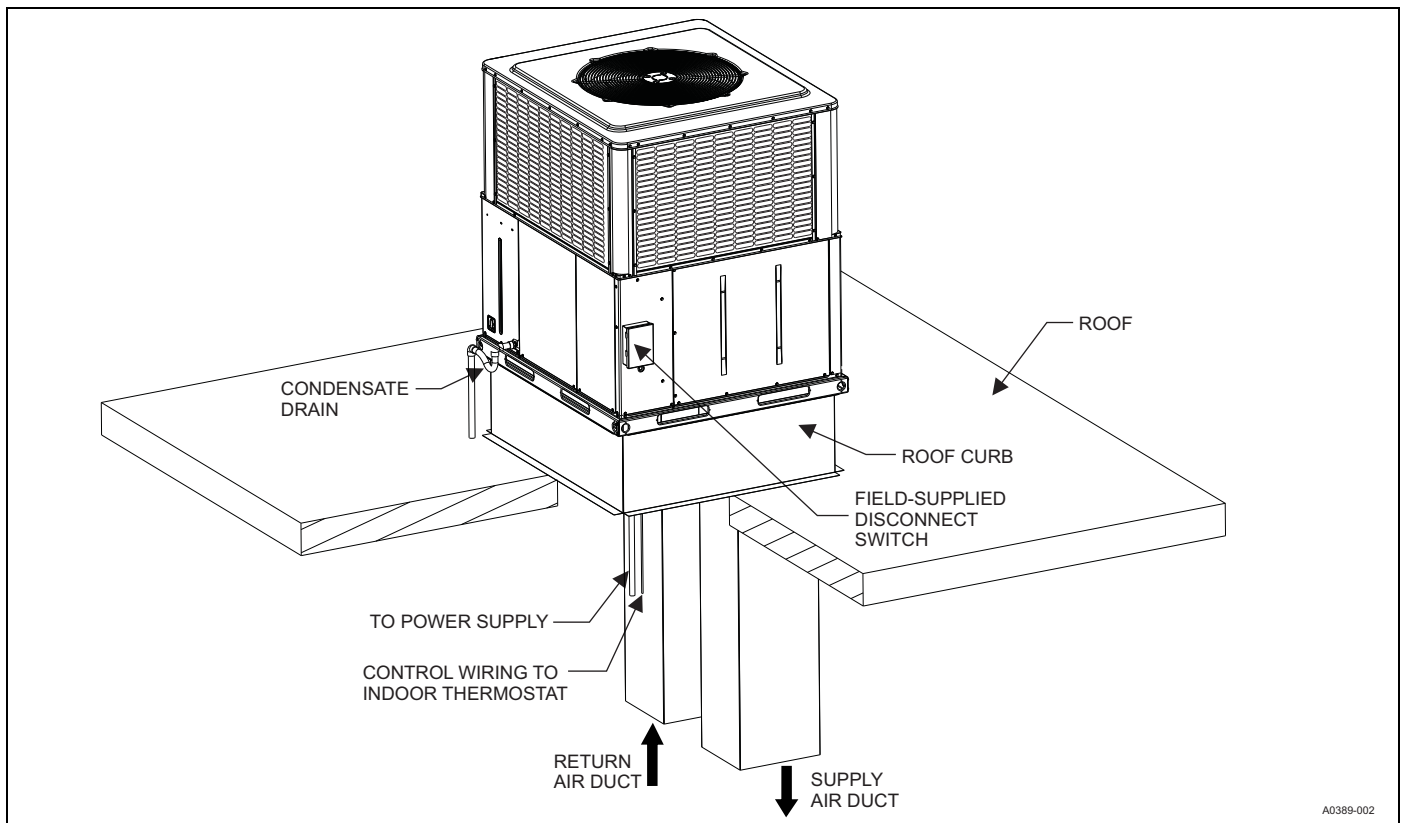

Third-Party Trademarks: For information about third-party trademarks, refer to the relevant company websites.